

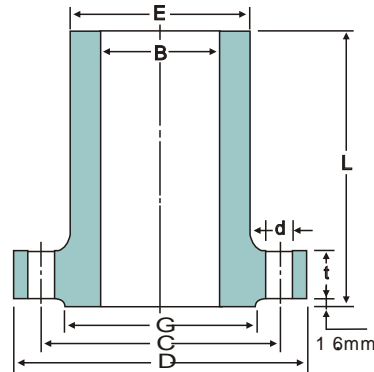

CLASS 400 / 600 FLANGES LONG WELDING NECK FLANGES



Unit :mm

Nominal Pipe Size	Outside Diameter	O .D .of Raised Face	Hub Diameter at Bevel	Diameter of Bore	Thickness of flange Min .	Length Through Hub	DRILLING		
							Diameter of Bolt Circle	Number of Holes	Diameter of Holes
	D	G	E	B	t	L	C		d
1 1 1/4 1 1/2 2 2 1/2 3 3 1/2	Use Class 600 dimensions in these sizes .								
4	254	157.2	146.1	101.6	35.1	304.8	200.2	8	25.4
5	279	185.7	177.8	127.0	38.1	304.8	235.0	2	25.4
6	318	215.9	206.2	152.4	41.1	304.8	269.7	12	25.4
8	381	269.7	260.4	203.2	47.8	304.8	330.2	12	28.4
10	445	323.9	320.5	254.0	53.8	304.8	387.4	16	31.8
12	521	381.0	374.7	304.8	57.2	304.8	450.9	16	35.1
14	584	412.8	425.5	355.6	60.5	304.8	514.4	20	35.1
16	648	469.9	482.6	406.4	63.5	304.8	571.5	24	38.1
18	711	533.4	533.4	457.2	66.5	304.8	628.7	24	38.1
20	775	584.2	587.2	508.0	69.9	304.8	685.8	24	41.1
24	914	692.2	701.5	609.6	76.2	304.8	812.8	24	47.8

Unit :mm

Nominal Pipe Size	Outside Diameter	O .D .of Raised Face	Hub Diameter at Bevel	Diameter of Bore	Thickness of flange Min .	Length Through Hub	DRILLING		
							Diameter of Bolt Circle	Number of Holes	Diameter of Holes
	D	E	G	B	t	L	C		d
1 1 1/4 1 1/2	124	53.8	50.8	25.4	17.5	228.6	88.9	4	19.1
	133	63.5	63.5	31.8	20.6	228.6	98.6	4	19.1
	155	69.9	73.2	38.1	22.4	228.6	114.3	4	22.4
2 2 1/2	165	84.1	91.9	50.8	25.4	228.6	127.0	8	19.1
	191	100.1	104.6	63.5	28.4	228.6	149.4	8	22.4
3 3 1/2	210	117.3	127.0	76.2	31.8	228.6	168.1	8	22.4
	229	133.4	139.7	88.9	35.1	228.6	184.2	8	25.4
4	273	152.4	157.2	101.6	38.1	304.8	215.9	8	25.4
5	330	190.5	185.7	127.0	44.5	304.8	266.7	8	28.4
6	356	222.3	215.9	152.4	47.8	304.8	292.1	12	28.4
8	419	273.1	269.7	203.2	55.6	304.8	349.3	12	31.8
10	508	342.9	323.9	254.0	63.5	304.8	431.8	16	35.1
12	559	400.1	381.0	304.8	66.5	304.8	489.0	20	35.1
14	603	431.8	412.8	355.6	69.9	304.8	527.1	20	38.1
16	686	495.3	469.9	406.4	76.2	304.8	603.3	20	41.1
18	743	546.1	533.4	457.2	82.6	304.8	654.1	20	44.5
20	813	609.6	584.2	508.0	88.9	304.8	723.9	24	44.5
24	940	717.6	692.2	609.6	101.6	304.8	838.2	24	50.8

Notes

- (1)Bore(B) is the not same as nominal pipe size.
- (2)Welding necks longer than listed are available in all sizes on special order.