

20K

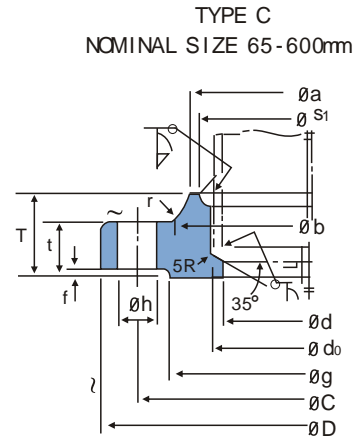
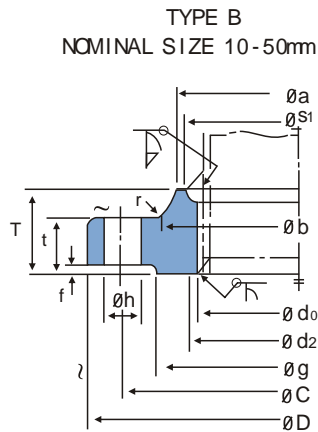
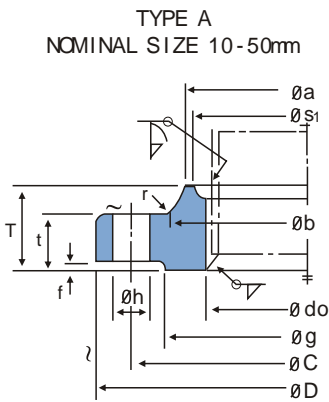

*The surface finish (~) is in the case of die forging

Unit :mm

Nominal Dia. of Flange	Outside Dia. of Steel Pipe	Inside Dia. of Flange do	Outside Dia. of Flange D	Sectional Dimensions of Flange Bolt Hole											Nominal Bolt Size	Hole Dia. h					Approx. Weigh (Kg)
				t	T	Dia. of Hub		Radius r	f	g	d	Bolt Circle Dia. c	Number of Bolt Holes	Hole Dia. h		S1	m	S2	n	l	
						a	b														
10	17.3	17.8	90	14	20	30	32	4	1	46	-	65	4	15	M12	27	4	27	4	-	0.59
15	21.7	22.2	95	14	20	34	36	4	1	51	-	70	4	15	M12	31	4	31	4	-	0.65
20	27.2	27.7	100	16	22	40	42	4	1	56	-	75	4	15	M12	37	4	37	4	-	0.81
25	34.0	34.5	125	16	24	48	50	4	1	67	-	90	4	19	M16	44	4	44	4.5	-	1.29
32	42.7	43.2	135	18	26	56	60	5	2	76	-	100	4	19	M16	52	4	53	5	-	1.60
40	48.6	49.1	140	18	26	62	66	5	2	81	-	105	4	19	M16	58	4	59	5.5	-	1.69
50	60.5	61.1	155	18	26	76	80	5	2	96	-	120	8	19	M16	70	4	72	5.5	-	1.89
65	76.3	77.1	175	20	30	100	104	5	2	116	65.9	140	8	19	M16	94	6	-	-	6	2.60
80	89.1	90.0	200	22	34	113	117	6	2	132	78.1	160	8	23	M20	107	6	-	-	6	3.93
(90)	101.6	102.6	210	24	36	126	130	6	2	145	90.2	170	8	23	M20	120	6	-	-	6	4.56
100	114.3	115.4	225	24	36	138	142	6	2	160	102.3	185	8	23	M20	132	6	-	-	6	5.13
125	139.8	141.2	270	26	40	166	172	6	2	195	126.6	225	8	25	M22	160	7	-	-	6	8.30
150	165.2	166.6	305	28	42	196	202	6	2	230	151.0	260	12	25	M22	186	8	-	-	6	10.6
200	216.3	218.0	350	30	46	244	252	6	2	275	199.9	305	12	25	M22	237	9	-	-	6	13.3
250	267.4	269.5	430	34	52	304	312	6	2	345	248.8	380	12	27	M24	290	10	-	-	6	23.4
300	318.5	321.0	480	36	56	354	364	8	3	395	297.9	430	16	27	M24	345	11	-	-	6	27.7
350	355.6	358.1	540	40	62	398	408	8	3	440	333.4	480	16	33	M30X3	384	12	-	-	6	39.2
400	406.4	409.0	605	46	70	446	456	10	3	495	381.0	540	16	33	M30X3	437	13	-	-	7	54.2
450	457.2	460.0	675	48	78	504	514	10	3	560	431.8	605	20	33	M30 3	490	15	-	-	7	71.7
500	508.0	511.0	730	50	84	558	568	10	3	615	482.6	660	20	33	M30 3	544	16	-	-	7	86.2
(550)	558.8	582.0	795	52	90	612	622	10	3	670	533.4	720	20	39	M36 3	595	16	-	-	7	105
600	609.6	613.0	845	54	96	666	676	10	3	720	584.2	770	24	39	M36 3	646	18	-	-	7	119
*650	660.4	664	945	60					5	790		850	24	48	M45 3						
*700	711.2	715	995	64					5	840		900	24	48	M45 3						
*750	762.0	766	1080	68					5	900		970	24	56	M52 3						
*800	812.8	817	1140	72					5	960		1030	24	56	M52 3						
*850	863.6	868	1200	74					5	1020		1090	24	56	M52 3						
*900	914.4	919	1250	76					5	1070		1140	28	56	M52 3						

- (1) Flanges of parenthesized nominal diameter had better not be used.
- (2) "d" is an example of pipe thickness for schedule 40 for nominal diaminal 400 and under ,and for schedule 12.7mm for 450 through 600 of KS B3562 and KS D3507(JIS G3454, JIS G3456).
- (3) The dimension of the notch (m,n,S1,S2) for welding can decided between concerned parties.
- (4) Nominal diameter over 600 is manufacturer's standard.